

Mouldflo

Mouldflo

INSTALLATION USER MANUAL

MOULDFLO A/S
Copyright © 2017

Mouldflo A/S
Dynamovej 11, 2tv
2860 Søborg - Denmark (DK)
CVR: 36459344

Tel.: +45 40 20 77 22
Sales@mouldflo.com
www.mouldflo.com

Contents

Preface Introduction	4
Warning	4
Disclaimer	4
Basic Safety Instructions.....	5
Warning indications.....	5
Proper use	5
Organisational Precautions	5
Safety Precautions in Relation with the Individual Operating Phases Normal running	6
Special precautions during use of the IMFMS, maintenance work and repair of malfunctions during operation; Disposal.....	6
Directions on Special Hazardous Elements Electrical supply.....	7
Risk of metallic corrosion.....	7
Risk of leaking	8
Required water quality.....	8
Dissolved compounds.....	9
Increased acid capacity by alkalinity of the inhibitor system	9
Risk of corrosion	9
Prior to start-up	10
Start-up procedure	10
Description of the system.....	12

Overview and use of the system	12
Technical specifications:	12
General Dimension	14
Flow Description	15
Installation.....	16
<i>Fitting Valves</i>	16
Service & Maintenance	18
Removing cover	18
Removing sensor Box.....	18
Sensor box complete removal.....	19
Removing sensor	19
Refitting sensor	21
Refitting sensor box	24
Cleaning the System.....	26
Change log	27

Preface Introduction

Please ensure to read all relevant **Installation User Guides (Manifold, interface and software)** through thoroughly before installing your new Mouldflo.

Warning

Please ensure that flow never exceeds the sensors' maximum. If pressurized air supply exceeds 0,5 bar, the flow sensors may be damaged due to extreme purge speed.

Flow must never exceed more than 10% of the maximum capacity; failure to comply with this precaution may damage the sensor.

During start-up and purge, always follow the **Quick Guide**.

For further information/details, please be referred to relevant **Instruction Manuals** which can be found on www.mouldflo.com.

Disclaimer

Costs connected to any damages to the products caused by lack of following the Instruction Manual, will be at the customers' own expense.

Basic Safety Instructions

IMPORTANT!

Warning indications

The manual describes particularly important information, hereunder information about correct use of IMFMS (Intelligent Mould Flow Monitoring System).

Please take note of special instructions and to injunctions to prevent damage, injuries or extensive property damage.

Proper use

The IMFMS is designed by using the latest technical knowledge and safety regulations.

Yet, during use, there can be a risk to cause hazard to the user or third party's life and body, respectively, cause damage to the IMFMS or other property.

The IMFMS may only be used under proper working conditions and only in accordance with its purpose. It can only be used safely when handling is done in compliance with the instruction manual. In particular, disruption, which may impair the safety, shall be promptly corrected.

The IMFMS is designed exclusively for the stated purpose. Any alternative or additional use is considered out of scope and therefore, the Manufacturer / supplier can not be made liable for damages resulting from such use. The risk is entirely the user's own.

Proper use also includes observance of operating instructions and compliance with service and maintenance instructions.

Organisational Precautions

In addition to the instruction manual, all other applicable safety and environmental regulations comply.

Prior to handling the product, the staff assigned to work by the IMFMS must have read the instruction manual thoroughly, not the least, the chapter on safety.

The owner of the product must ensure that staff uses the IMFMS safely in accordance with the instruction manual.

All safety and warning instructions on the IMFMS must be respected.

If there are safety or operational changes to the IMFMS, please stop immediately and notify disturbance to the responsible person.

Do not make changes, expansions and renovations on the IMFMS which could impact the safety without seeking the supplier's permission beforehand.

Spare parts must conform to the technical requirements established by the manufacturer; these requirements are always met by original spare parts.

Safety Precautions in Relation with the Individual Operating Phases Normal running

Any unsafe working methods should be omitted.

Take any necessary precautions in order to ensure that the IMFMS is only used in safe working environment.

In case of any dysfunctions, the IMFMS must be stopped immediately and secured. Malfunctions must be corrected immediately.

Special precautions during use of the IMFMS, maintenance work and repair of malfunctions during operation; Disposal

The manual prescribed settings, maintenance and service intervals and instructions for replacement parts / equipment must always be respected. This work must only be performed by skilled personnel.

Maintenance and service intervals and instructions for replacement parts / equipment must always be respected. This work must only be performed by skilled personnel.

Before the IMFMS is cleaned with water or other cleaning agents, for safety and functional reasons, all openings must not be exposed to water or detergent, and must be covered / bonded. Particularly electric motors, connectors and cabinets are vulnerable. After cleaning, remove all covering / adhesives.

We strongly recommend safe and environmentally conscious disposal of operating equipment and aids as well as replacement parts!

Directions on Special Hazardous Elements Electrical supply.

Only use original fuses with the prescribed amperage. If disruption / malfunction of the electrical energy supply occur, then stop the IMFMS immediately.

Working on electrical systems or equipment must only be performed by an electrician or by trained personnel and must be done under supervision and in compliance with electrical regulations.

When performing inspection-, maintenance- and repair work, IMFMS parts must be made electricity free. It should first be checked that these parts are disconnected (electrical), and then they are grounded and short circuited. Parts which are mounted near parts which still are electrical connected, must be insulated.

The IMFMS electrical equipment must be inspected every 6 months. Defects such as loose connections must immediately be corrected.

Risk of metallic corrosion



Galvanic corrosion will occur when different metals are used in the same water installation. This can potentially lower the lifetime of the product.

Be aware that insufficient grounding of machine parts included in the water system can increase the corrosion of metal parts.



Corrosion will occur very rapidly if the fluid in the system has PH values higher than 8 or lower than 5. This will potentially lower the lifetime of the product.

⚠ DANGER

Risk of leaking

Metal corrosion will accrue and can cause leakage. Please make frequent inspections and maintenance of the manifolds metal to prevent this.

Failure to follow these instructions can result in death, serious injury, or equipment damage.

Required water quality

The cooling water has to fulfill certain requirements, depending on the type of cooling or tempering of products.

Check the quality of cooling water to protect the environment and machines from corrosion and deposition.

The recommended procedure to treat and/or care the cooling water is based on:

- Water ingredients
- Degree of contamination
- Materials used
- Type and size of cooling or tempering products

	Units	Cooling circuits
Temperature <input type="checkbox"/>	°C	< 90°C
Water pH range	-	5-8
Conductivity	S/cm	2000
Total hardness	mol/m ³	(2) 0.9
	°dH	(12) 5
Acid capacity (KS4,35)	mmol/l	4
Carbonate	°dH	23
Chloride	mg/l	(80) 50

Iron Fe ₂ , 3)	mg/l	1
Copper Cu ₂ , 3)	mg/l	0.5
Sulfate SO ₄)	mg/l	100
Bioburden ₆)	KBE/ml	10,000
Solids	mg/l	nothing

All values only apply in conjunction with an appropriate cooling water treatment and the use of suitable treatment agent.

Iron and copper compounds may stay dissolved and undissolved in the cooling water. Contents of iron and copper in the cooling system may provide an indication of corrosion in the cooling circuits as well as of possible deposits in the heat sources. During the start-up phase and load variations, iron and copper concentrations may rise according to experience.

Dissolved compounds

When using inhibitors, higher concentrations may be permitted in individual cases (then it is necessary to monitor the corrosion).

Increased acid capacity by alkalinity of the inhibitor system

A biocide (adding discontinuously) should be used if the number of germs increases above 10.000/ml.

Closed = hermetically sealed from the ambient atmosphere and pressure overload.

 **WARNING**

Risk of corrosion

If there are any faults or damages to the manifold or sensors caused by different water quality, we cannot guarantee the lifetime.

 **WARNING**

Prior to start-up

Please ensure that flow never exceeds the sensors' maximum. Check the label on the manifold to identify the flow sensor type:

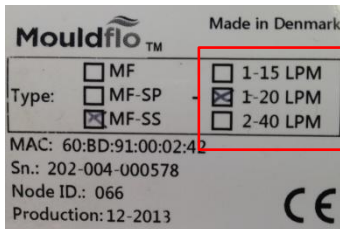

Flow must never exceed more than 10% of the maximum capacity; failure to comply with this percussion may damage the sensor.

Start-up procedure

During start-up (empty mould and manifold)

1. Fully open all mini ball valves to/from the mould.
2. Open the main return outlet valve on the manifold.
3. Slowly open the main inlet valve on the manifold and start filling the system.
4. Adjust the inlet flow to match only the flow needed.
5. Let it run until all air is out of the system before fully opening the main valve.

Purging (emptying Mould with pressurized air)

Way ball valve is recommended to be installed on main inlet and outlet of the manifold. Pressurized air inlet must be adjustable (pressure reducer)

1. Turn the main inlet valve in blocked/closed position.
2. Turn the main outlet valve in "drain" position.
3. Turn the main inlet valve in "pressure air in position".
4. Open the adjustable air **without exceeding 0,5 bar**, and ensure slow purge of water.
5. When system is almost empty you can open the air supply to blow circuits dry.

Warning: if pressurized air supply exceeds 0,5 bar, the flow sensors may be damaged due to extreme purge speed.

Description of the system

Overview and use of the system

The Intelligent Mould Flow Monitoring System also described as “IMFMS”, is produced as an independent system solution, with the ability to interact and communicate with machines and network connected to it.

The IMFMS is capable of measuring, monitoring and logging data from a given number of ports. Furthermore, the IMFMS is capable of sending signals, warnings, activating and deactivating any connected machinery.

Technical specifications:

Model	
Type:	IMFMS01
No.:	01
Anno:	2013
Manifold	
Size: (W x H x D)	4 Port: 180x125x275 8 Port: 180x125x475 12 Port: 180x125x675
Weight: (Approximate)	4 Port: 7 Kg 8 Port: 11 Kg 12 Port: 15 Kg
Supply	
MF-TS154:	100-240V 50-60Hz 1P+N 200VA 10 Amp IK MAX 4kA
MFIO:	12 – 24 VDC 1 Amp
System	
Noise Level	≤ 70 dB
Measuring range	1-15 l/min & 2-40 l/min

All units are metric unless otherwise specified

Length = Millimetre (mm)
Weight = Gram (g) /
Kilogram (Kg)
Pressure = Bar
Time = 24 hour Clock
Annotation = 1000 is typed
1.000,00

Accuracy ($\pm 1\sigma$), 0 to 100 °C	± 1.5 % FS
Response time (63.2 %)	< 1 s
Resolution	0.2 l/min
System burst pressure	> 5 bar

Temperature

Measuring range	0 to 100 °C
Accuracy ($\pm 1\sigma$), 25 to 80°C	± 1 °C
Accuracy ($\pm 1\sigma$), 0 to 100°C	± 2 °C
Response time (63.2 % at 50 %FS flow)	< 1 s
Resolution	0.5 °C

Media and environment

Liquid/Media types	
The sensor is compatible with liquids:	(kinematic viscosity ≤ 2 mm ² /s)
Media temperature	(operation) 0 to 90 °C
Media temperature	(peak) -25 to 120 °C, non-freezing
Ambient air temp.	(operation) -25 to 60 °C
Ambient air temp.	(peak) -55 to 85 °C
Humidity	0 - 95 % (relative), non-condensing

General Dimension

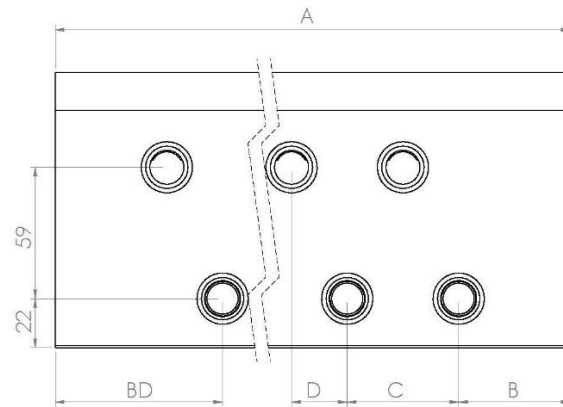
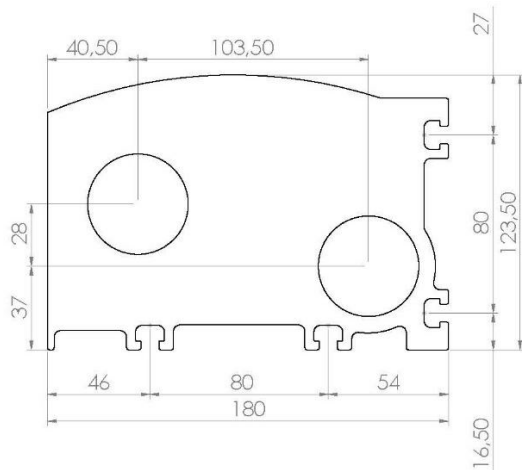

Model	Ports	A	B	C	D	BD
MF-4-x	4	275	50	50	25	75
MF-8-x	8	475	50	50	25	75
MF-12-x	12	675	50	50	25	75

Distance Between Mounting Tracks: 80mm

Water Inlet & Outlet: G 1 ½" (BSP)

Port Valve Inlet & Outlet: G ½" (BSP)

Flow Description

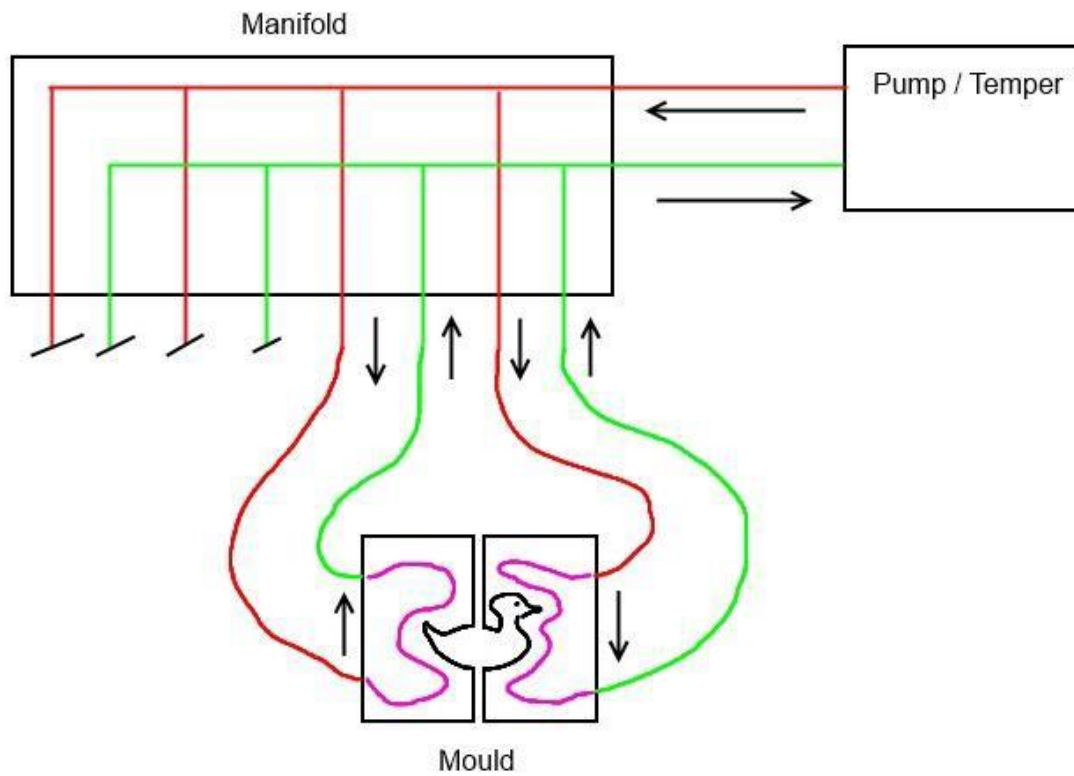
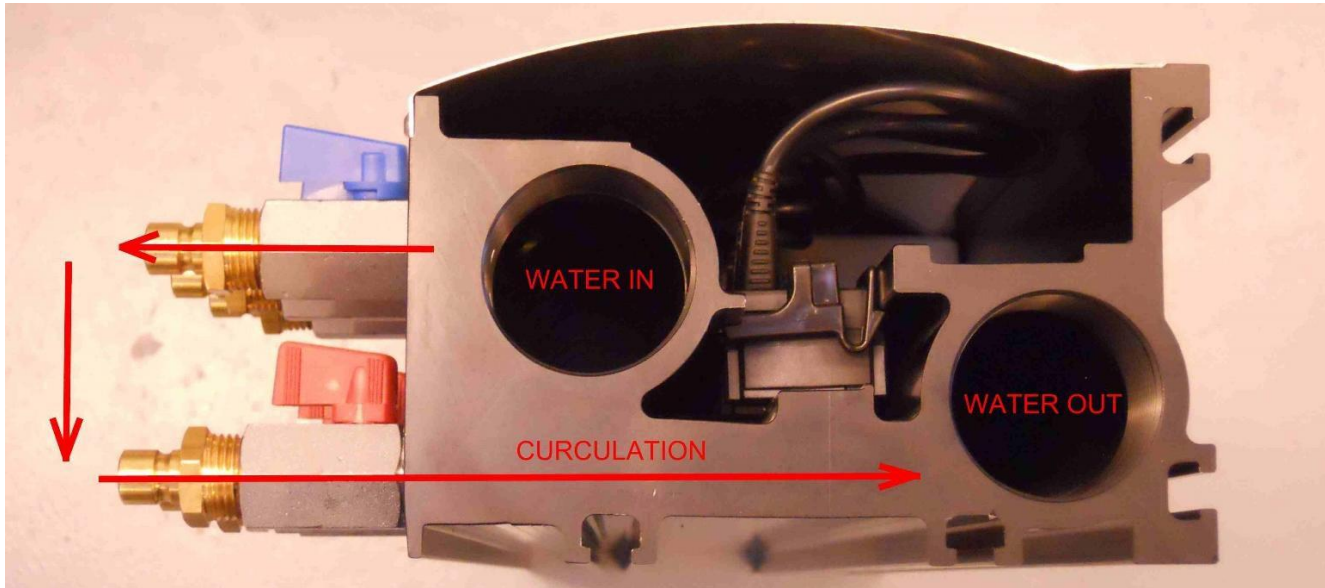

Installation

Fitting Valves



1. Start in one end and on the top row.



2. Tighten the valve so the valve handle is not in the way of the other valves.



3. Ensure the handles are placed where intended

for use

Mouldflo A/S

Dynamovej 11, 2tv

2860 Søborg - Denmark (DK)

CVR: 36459344

Tel.: +45 40 20 77 22

Sales@mouldflo.com

www.mouldflo.com



4. When the top row is fitted, then start the lower row.

Service & Maintenance

Important! Before disassembling anything, empty the system of water, and disconnect water and power supply.

Removing cover

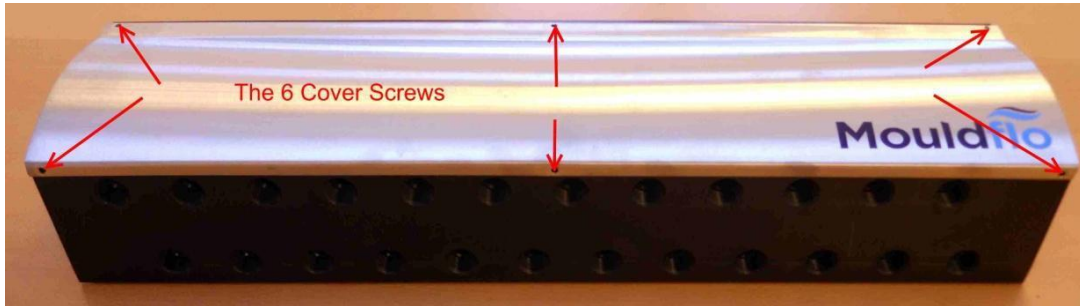

Remove the 6 cover screws. (M4x6) then lift off the cover.

Removing sensor Box



1. Remove the cover.



2. Remove the nut, holding the ground wire (M4).

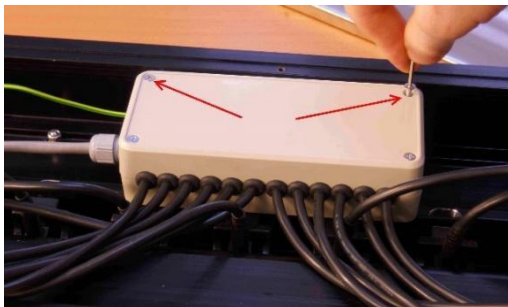

3. Remove the 2 Hex screws (M3x45 countersunk).

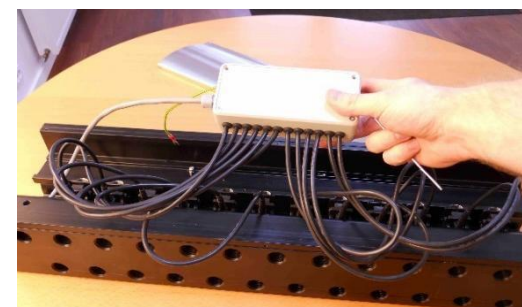

4. Lift out the box.

Sensor box complete removal

1. Gently unsnap the wireplug with a small straight notch screwdriver in each side and pull off the wire plug.



2. To remove the inlet temperature sensor.



3. Push down the blue ring while pulling the sensor.

Removing sensor



1. Locate the sensor that needs replacing



2. Release the metal clips manually or with a small plier.



3. Remove the clip



4. Remove sensor and make sure the 2 sealing rings (o-rings) are removed as well



5. Gently unsnap the wireplug with a small straight notch screwdriver in each side.



6. Pull out the plug.



7. Make sure the sealing rings are not left in the sensor hole in the manifold

Refitting sensor



1. Make sure that both sealing rings are on the new sensor.



2. Gently place the sensor in the sensor hole.



3. Then push down the sensor, so the sealing rings are sealed tight.



4. Place the clips over the sensor, so that the socket is accessible.



5. Push the down the clips, so it snap locks in both sides.

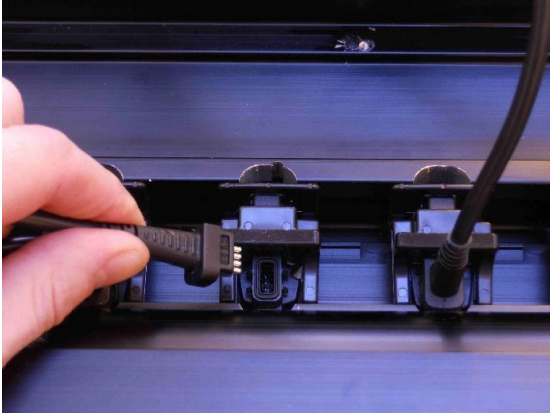

6. Gently connect the plug, be careful not to bend any of the sensor pins in the socket.

Refitting sensor box



1. Place the sensor box over the mounting holes.



2. Refit the 2 M3x45 countersunk mounting screws.



3. Connect the wire to the grounding pin.



4. Refit the M4 nut, so the wire does not come off.

Then refit the cover.



5. Push the temperature sensor into the blue fitting, and try to pull it to secure that it is fastened.

Cleaning the System

All surfaces shall be cleaned with a piece of cloth soaked in soap water or any other non-corrosive cleaning agent, concerned aluminium, steel and brass.

Furthermore, we recommend descaling the system by using Mouldpro Remover Plus Powder Descaling Agent.

Find more information on www.mouldpro.com.

Change log

Revision	Author	Date	Comments
	IS	26/03/2018	Redesigned to new template